

SECTION A-A
BRICK WALL

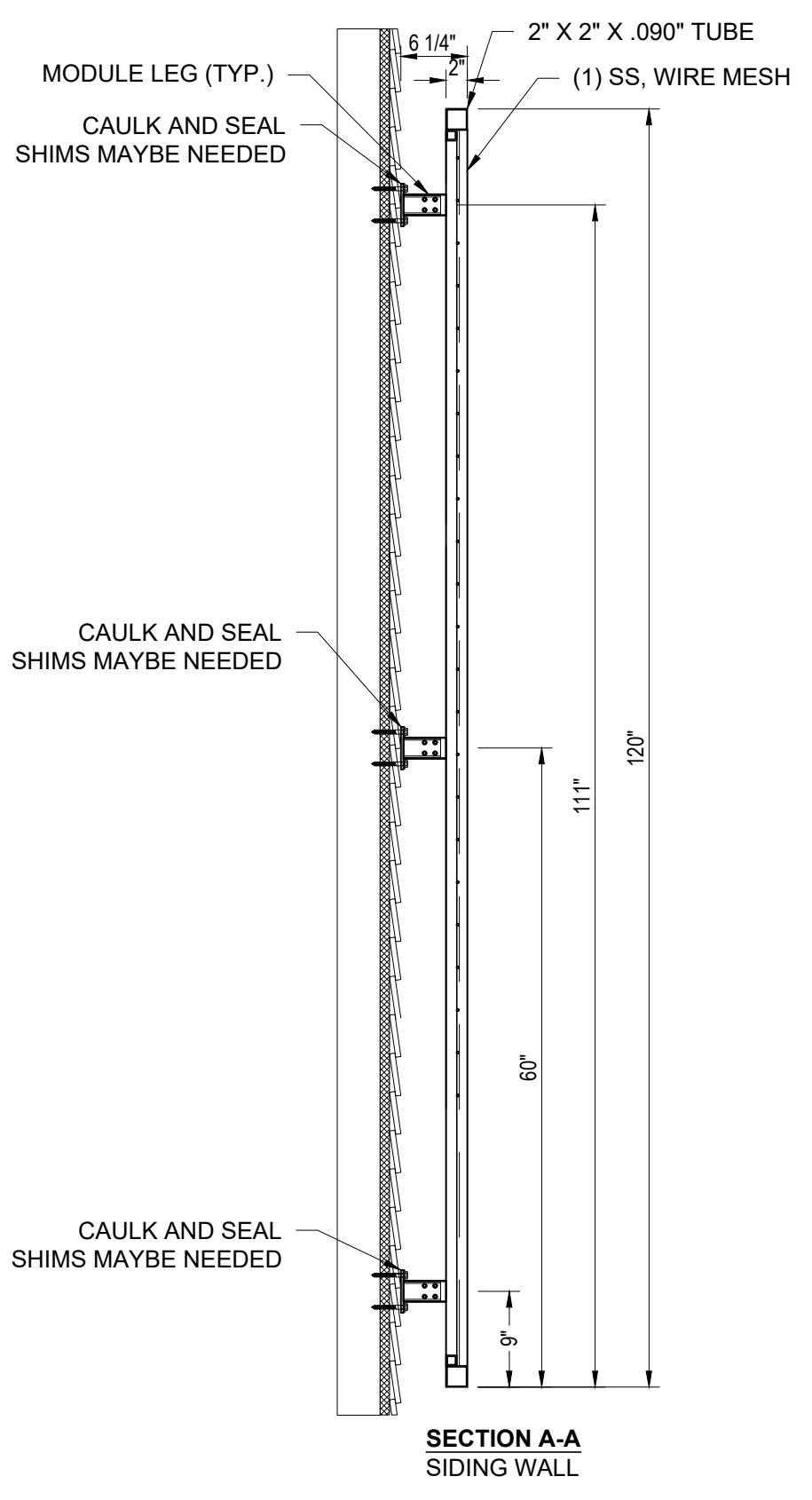

SECTION A-A
SIDING WALL

FRAME DETAIL

PROJECT NAME: AWNEX - GREEN SCREEN - 60"x120"		DESCRIPTION	
DRAWING NAME: INSTALLATION SECTION		PRODUCTION	
CUSTOMER:		BY	
REV	DATE	DRD	
	11/30/20		

SHIPPING ADDRESS:
AWNEX, INC
IN-HOUSE

CONTRACTOR:
N/A
CONTACT: N/A
PHONE: N/A

TOLERANCES U.N.O.
X/XX = ± 1/8"
.XX = ± .03"
.XXX = ± .005"

DWN BY:	CHK BY:	ENG. BY:
DRD	--	---

SCALE: 1"=1'-0"

SHT. NO: **I-1.00**